

HYDRIVE

2010A - 2020A



INSTALLATION
OPERATION
MAINTENANCE
SAFETY
STORAGE

HYDRAULICS COOLERS

SAFETY, STORAGE, INSTALLATION, OPERATION AND MAINTENANCE INSTRUCTIONS MODELS : HYDRIVE 2010A & 2020A



Cooler N° :

Date of bringing into service :

TABLE OF CONTENTS	Page
1. OVERALL DIMENSIONS	3
2. TECHNICAL DATA	4
3. INSTALLATION	4
3.1 Hydraulic circuits	4
3.2 Mounting the HYDRIVE	6
3.3 Hydraulic oil	9
3.4 Priming the system	9
3.5 Engaging Hydraulic Motor	10
3.6 Adjusting the relief valve	10
3.7 Setting HYDRIVE fan speed	11
4. OPERATION	12
4.1 HYDRIVE pre-start up check list	12
4.2 HYDRIVE operation	12
5. MAINTENANCE	13
5.1 Maintenance schedule	13
5.2 Return filter replacement	13
5.3 Fan replacement	13
6. TROUBLESHOOTING	14
7. STORAGE CONDITIONS	15
8. SCRAPPING	15
9. CERTIFICATE OF CONFORMITY	16

SAFETY INFORMATIONS



This is a SAFETY ALERT SYMBOL

When you see this symbol on the product, or in the manual, look for one of the following signal words and be alert to the potential for personal injury, death or major property damage.



Warns of hazards that **WILL** cause serious personal injury, death or major property damage



Warns of hazards that **CAN** cause serious personal injury, death or major property damage.



Warns of hazards that **CAN** cause personal injury or property damage.

NOTICE

Indicates special instructions which are very important and must be followed.

NOTICE :

The HYDRIVE **MUST** only be installed in systems which have been designed by qualified engineering personnel. The system **MUST** conform to all applicable local and national regulations and safety standards.

This manual is intended to assist in the installation and operation of the HYDRIVE and **MUST** be kept with the HYDRIVE.

HYDRIVE service shall be performed by qualified technicians **ONLY**. Service shall conform to all applicable local and national regulations and safety standards.

Thoroughly review this manual, all instructions and hazard warnings, **BEFORE** performing any work on the HYDRIVE

Gloves shall be worn when handling sheet metal to avoid any risk of injury.

Maintain **ALL** system and HYDRIVE operation and hazard warning decals.

NOTE :

Numbers in parentheses following individual parts indicate reference numbers on the corresponding Parts Lists.

1. OVERALL DIMENSIONS

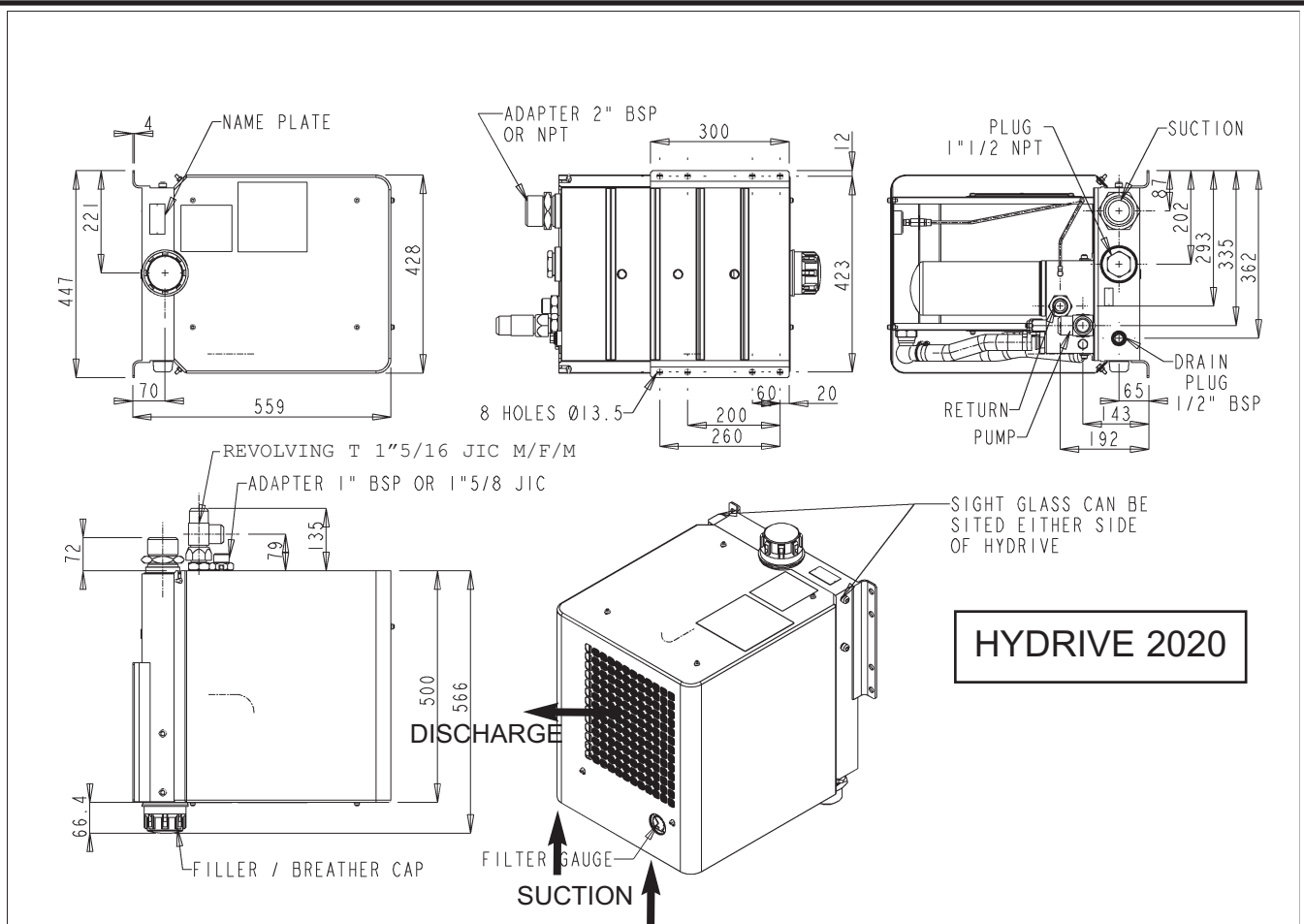
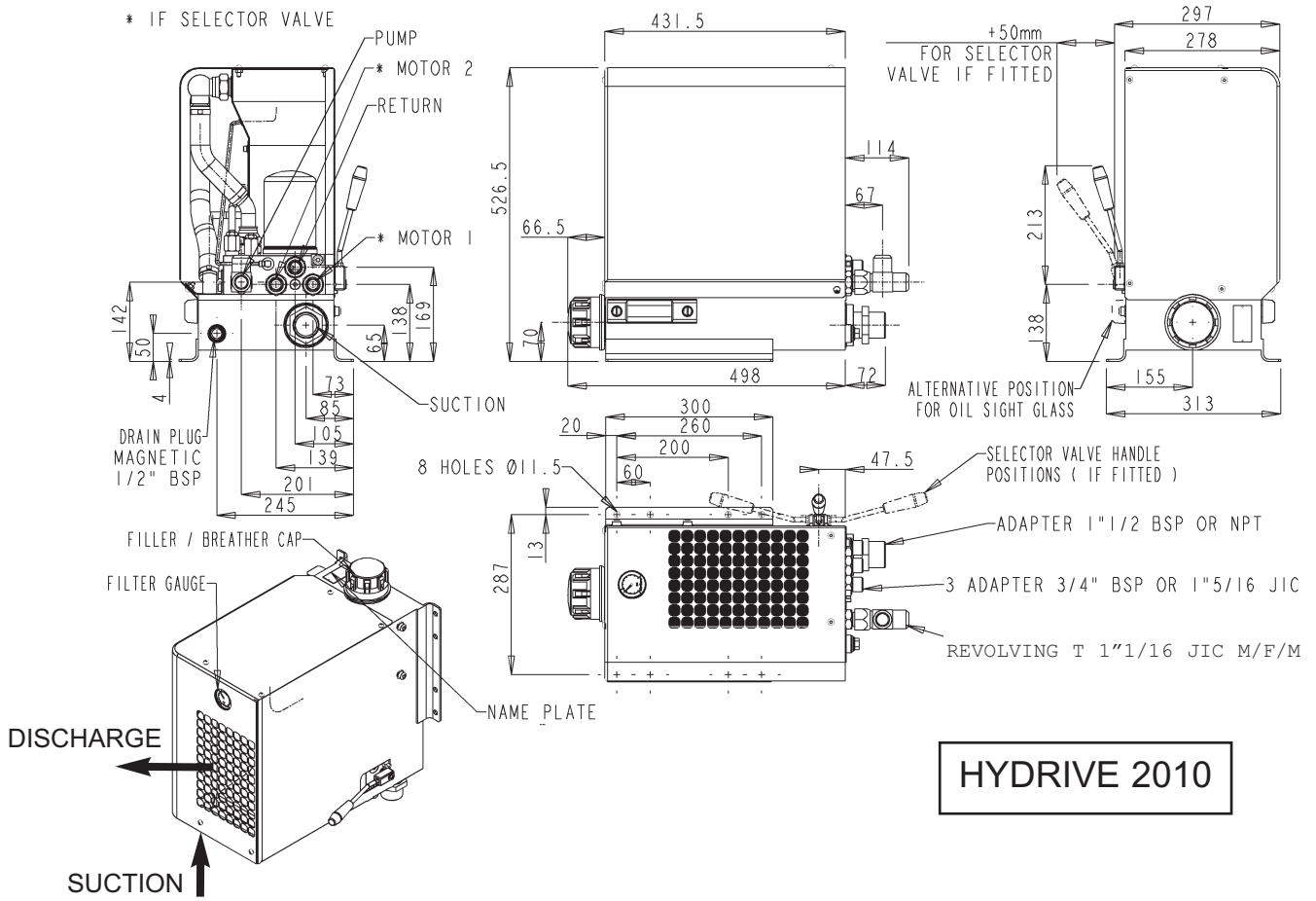

2. TECHNICAL DATA

HYDRIVE 2010A		
Oil Flow Rate	15 - 32 US GPM	55 - 120 l / min
Circuit pressure 2 possible versions : 170 bar 270 bar Maximum pressure allowed	RV set @ : 2465 PSI 3916 PSI 4061 PSI	RV set @ : 170 bar 270 bar 280 bar
Fan speed	2800 rpm	2800 rpm
Return pressure	15 - 75 PSI	1 - 5 bar
Heat Dissipation	13.5 HP for 70°F temperature rise	10 kw for 40 °C Temperature rise
Fan Motor Flow	1.5 U.S GPM	5.5 l / min
Weight (Dry)	53 lbs	24 kg
Oil Tank Capacity	2.5 US Gallons	10 liters

HYDRIVE 2020A			
Oil Flow Rate	2020 - 150 2020 - 200	15 - 40 US GPM 15 - 53 US GPM	55 - 150 l / min 55 - 200 l / min
Circuit pressure Maximum pressure allowed	RV set @ 3625 PSI 4061 PSI	RV set @ 250 bar 280 bar	
Fan speed	2800 rpm	2800 rpm	
Return pressure	15 - 75 PSI	1 - 5 bar	
Heat Dissipation	26 HP for 70°F temperature rise	20 kw for 40 °C Temperature rise	
Fan Motor Flow	2.2 U.S GPM	8.2 l / min	
Weight (Dry)	77 lbs	35 kg	
Oil Tank Capacity	4.5 US Gallons	17 liters	

3. INSTALLATION

3.1 Hydraulic circuits

Figure 1 shows the hydraulic circuit for a single motor drive system (without selector valve). If driving a motor in both directions, install a directional control valve in the circuit as shown (figure1).

The HYDRIVE is NOT suitable for use for systems using tipping rams (hydraulic cylinders).

NOTE

Use bulkhead fittings to prevent any overstressing of the hoses and connections between the tractor and trailer.

NOTICE :

The HYDRIVE must only be installed in systems designed by qualified engineering personnel. System design must conform with all applicable regulations and codes and must provide warning of all system hazards.

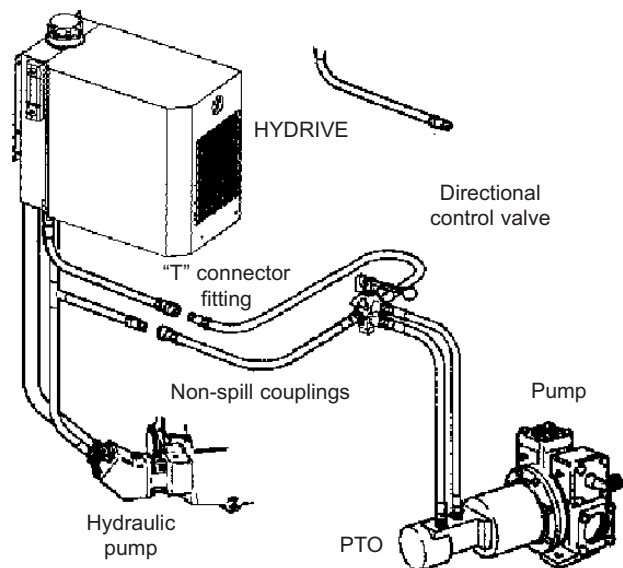

Figure 1
System layout without selector valve

3. INSTALLATION (continued)

There are 2 versions of the HYDRIVE 2010, standard version and selector valve version. (NOTE : Use a remote on / off valve on hydraulic systems using the hydrive 2010 without the selector valve).

The selector version features a manually operated spool valve so that the high pressure oil (from the hydraulic pump) can be switched between two possible hydraulic motors (Motor 1 & Motor 2). The valve can also be set to neutral position with the system unloaded, and the oil returning back to the tank.

The selector version is designed for tanker applications where both a compressor and pump may be installed on a vehicle but operated separately. HYDRIVES are NOT suitable for use with hydraulic cylinders.

The selector valve is NOT available for the HYDRIVE 2020 model.

The HYDRIVE 2010 is not designed for use with 2 motors running simultaneously unless the system is designed to allow multi motor operation.

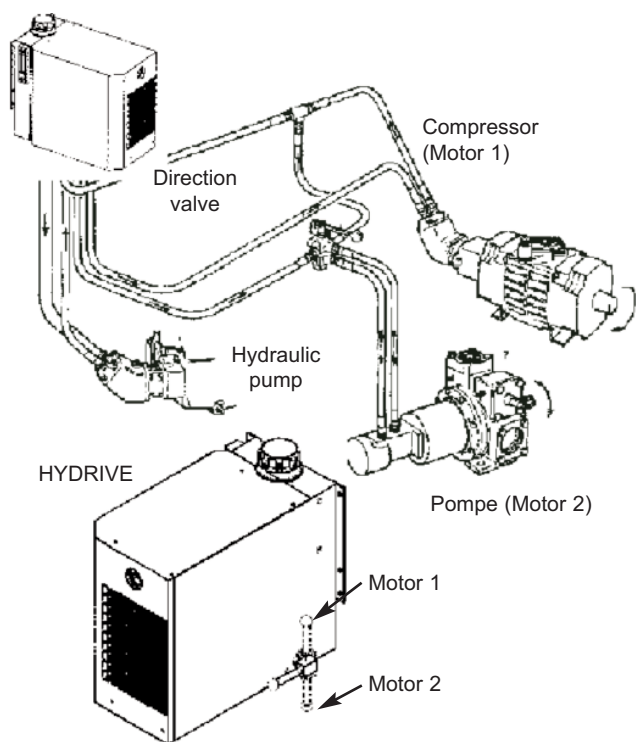
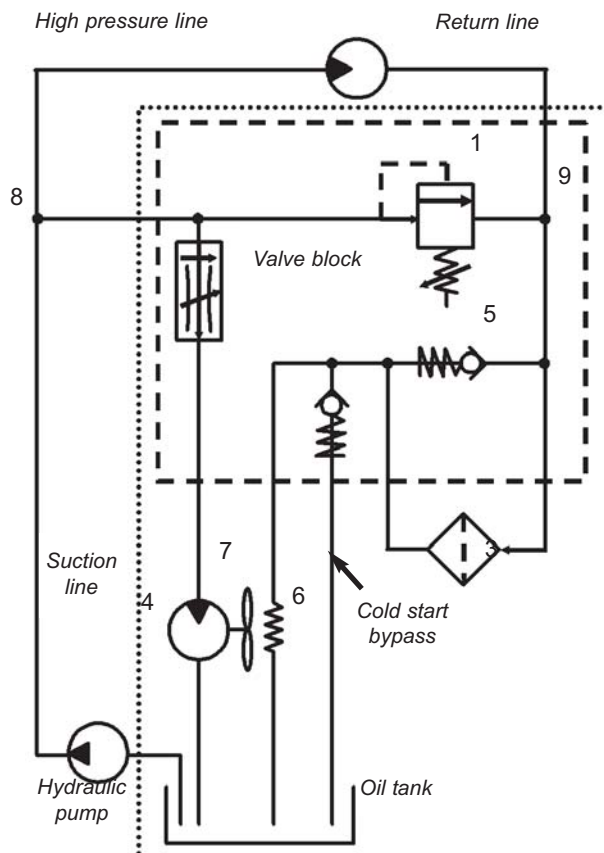

Figure 2
HYDRIVE 2010 with selector valve

3.1.1 STANDARD HYDRIVE 2010A & 2020A HYDRAULIC CIRCUIT



1. Adjustable relief valve
2. Fan speed control valve
3. Return line filter
4. Fan motor
5. Filter by-pass valve
6. Oil cooler radiator
7. Fan
8. System pressure gauge point (not accessible for the 2010)
9. Return pressure gauge point

NOTES

THE DRIVEN MACHINE, PUMP OR COMPRESSOR, WILL START AUTOMATICALLY WHEN THE HYDRAULIC PUMP IS ENGAGED UNLESS A REMOTE ON/OFF CONTROL VALVE IS INSTALLED IN THE SYSTEM.

A cold start bypass protects the cooler and quickly warms the oil to its normal working temperature.

3. INSTALLATION (continued)

3.1.2 HYDRIVE 2010A HYDRAULIC CIRCUIT - SELECTOR

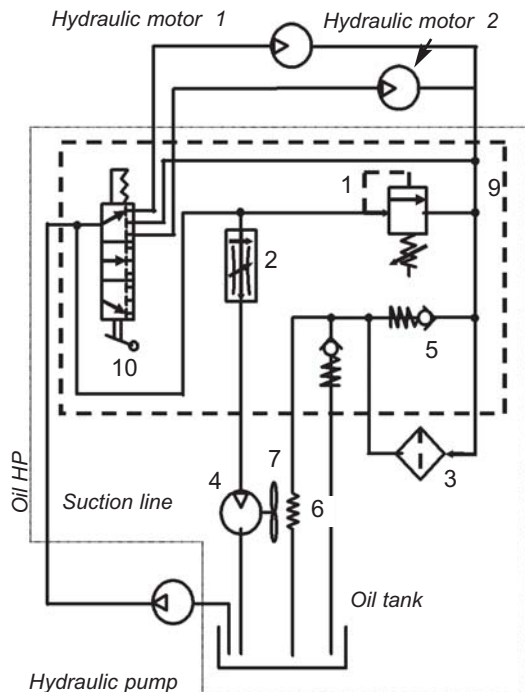

1. Adjustable relief valve
2. Fan speed control valve
3. Return line filter
4. Fan motor
5. Filter by-pass valve
6. Oil cooler radiator
7. Fan
9. Return pressure gauge point
10. Selector



The HYDRIVE must be mounted as high above the hydraulic pump as possible to avoid hydraulic pump cavitation.

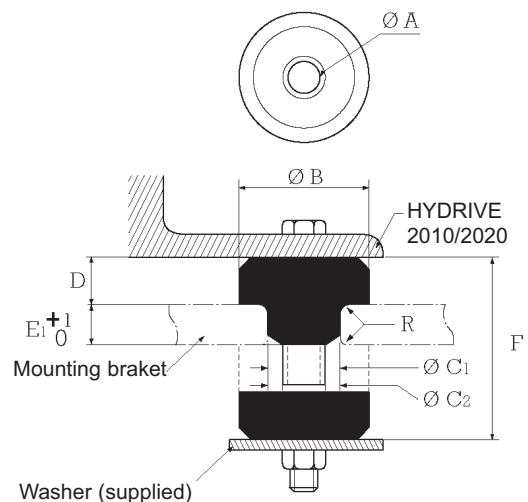

- C1 : Metallic bore Ø
 C2 : Dampener Ø
 F : Free height
 R : Necessary radii on angles

Using the supplied washers contributes to the vibration protect.

3.2 Mounting the HYDRIVE

1. Position the HYDRIVE so that the filler cap (5) and sight glass (6) are accessible, and that the front of the radiator (44) (where the air exits) is not obstructed.

NOTE - For easy installation, the sight glass can be mounted on either side of the HYDRIVE tank.

2. The HYDRIVE must be mounted using at least four of the eight mounting holes and the anti-vibration pads supplied (see Figures 3 and 4 below regarding mounting dimensions). The minimum distance between attachment points must be 7 inches (180 mm).

Do not put any strain on the tank fabrication (2) or distort the mounting lugs.

To help reduce the vibration and stress between the truck frame and HYDRIVE, users may install additional mounting brackets to offset the HYDRIVE from the frame rail and adapt the anti-vibration pads supplied. The brackets are application specific and must be made by the installer when needed.

	Ø A mm	Ø B mm	Ø C1 mm	Ø C2 mm	D mm	E1 mm	F mm	R mm	Weight g
2010	10,4	33,2	19	20,1	12,3	9,5	31,7	1	43
2020	13,5	47,7	31,7	33	19,8	14	49,2	1,5	142

3. Mount the HYDRIVE in a position away from the wheels and road spray to protect the radiator from impact damage from road debris, stones, loose hoses, etc. (see Figure 3).
4. Allow provisions and space to install test equipment in the discharge line of the HYDRIVE (see Figure 4).

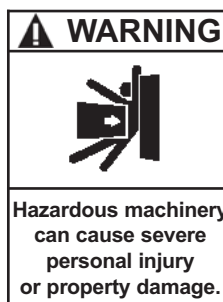

SET THE VEHICLE EMERGENCY BRAKE AND CHOCK WHEELS BEFORE ATTEMPTING MAINTENANCE OR SERVICE.

3. INSTALLATION (continued)

3.2.1 CONNECTING THE HYDRIVE

1. Connect the suction hose from the HYDRIVE valve block port marked "Pump" to the inlet of the hydraulic pump via bulkhead fittings. The suction hose must be a steel wire reinforced, vacuum rated, suction hose. See chart below.

Do not put any strain on the tank fittings. The suction hose must be as short as possible, without any tight bends or kinks. The hose must also be free of air leaks.

To minimize the possibility of cavitation, use the following hose size guidelines :

Hose bore size	Maximum recommended flow	
1½" (38mm)	26 US GPM	98 l/min
2" (50.8mm)	32 US GPM	120 l/min
2½" (63.5mm)	48 US GPM	180 l/min

NOTE

Hose length must follow hose manufactures recommendations.

2. Pressure and return hoses must be connected using pressure (swaged) type fittings, installed to the hose manufactures recommendations.
3. All seals must be made using bonded washers, O-ring or coned fittings.

MOUVEX does not recommend the use of PTFE tape or liquid sealant, as these may contaminate the hydraulic oil or plug the system.



SYSTEM FITTINGS AND HOSES MUST BE CAPABLE OF WITHSTANDING OPERATING PRESSURES.

4. Some hydraulic pumps and motors require a case drain to return to the HYDRIVE tank. For these applications, remove the HYDRIVE tank drain plug (9) and connect the drain line to ½" BSP female connection (Figure 4, Item 4).

For HYDRIVE 2010's with selector valve option, go to the step 1, Section 3.2.3.

3.2.2 HYDRIVE WITHOUT SELECTOR VALVE

1. Connect a high pressure hose from outlet of the hydraulic pump to the inlet of the hydraulic motor. Insert a "T" connector into this line and connect to the fitting on the control block marked "MOTOR" (see Figure 1).
2. Connect the low pressure return hose from the driven motor to the fitting on the control block marked "RETURN". The return hose must be rated for minimum 300 PSI (20 bar) working pressure (Figure 4, Item 4).

For HYDRIVE 2010 without selector valve and HYDRIVE 2020, go to the step 3, Section 3.2.3.

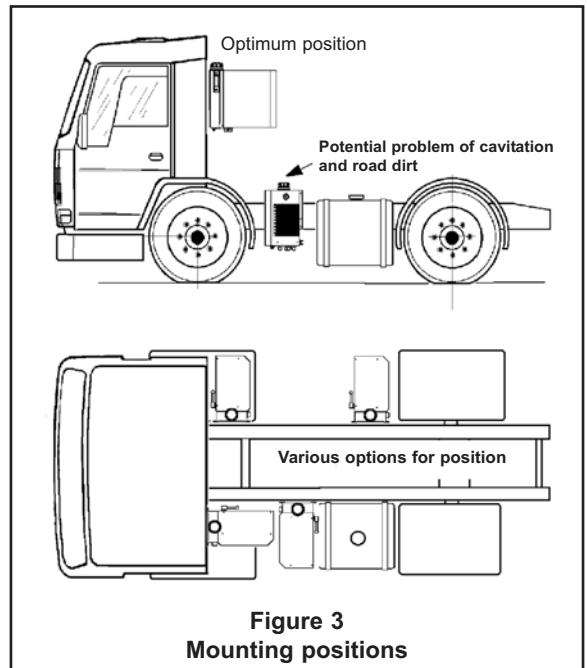

Figure 3
Mounting positions

3.2.3 HYDRIVE WITH SELECTOR VALVE

1. Connect a high pressure hose from the male fitting on the control block marked "MOTOR 1", to the intake of the hydraulic motor (i.e. on the compressor). Connect the fitting on the control block marked "MOTOR 2" to the intake of the second hydraulic motor (i.e. on the MOUVEX pump).
2. Using a "T" fitting, connect the low pressure return hoses from both to the male fitting on the control block marked "RETURN". Use a return hose, rated to a minimum 300 PSI (20 bar) working pressure (Figure 5, Item 3).

NOTICE

For HYDRIVES fitted with the selector valve both "MOTOR 1" & "MOTOR 2" MUST be connected to HYDRIVE valve block fittings.

3. INSTALLATION (continued)

3. On tractor/truck and semi-trailer mounted applications, hoses/piping to the hydraulic motor must be connected by quick release (non-spill) couplings. To reduce back-pressure on the motor, one size larger couplings than the return line must be used.

NOTICE

QUICK RELEASE COUPLINGS MUST BE PROTECTED FROM CONTAMINATION AND DAMAGE AND BE PROPERLY CLEANED BEFORE RE-CONNECTION.

WARNING



Hazardous pressure can cause personal injury or property damage.

QUICK RELEASE COUPLINGS MUST BE FULLY CONNECTED. FAILURE TO DO SO CAN CAUSE PERSONAL INJURY OR PROPERTY DAMAGE.

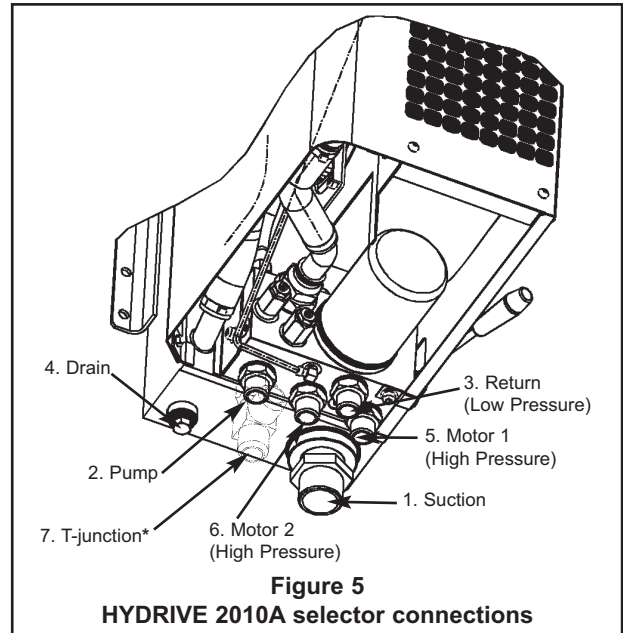
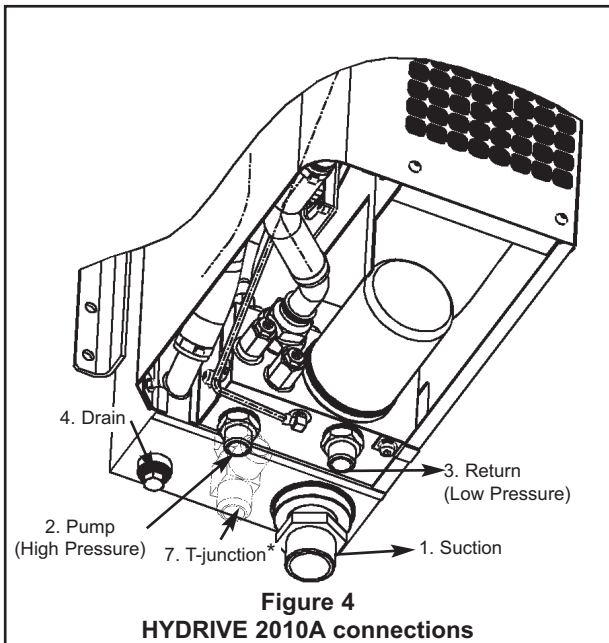

Hydrive Connections			
	Hydrive 2010	Hydrive 2010 selector	Hydrive 2020
1 Suction	<i>1 1/2 inch NPT M</i> 1 1/2 inch BSP M		<i>2 inch NPT M</i> 2 inch BSP M
2 Pump Return	<i>1 1/16 inch - 12 JIC M</i> 3/4 inch BSP M		<i>1 5/16 inch - 12 JIC M</i>
3 Motor Return	<i>1 5/16 inch - 12 JIC M</i> 3/4 inch BSP M		1 inch BSP M <i>1 5/8 inch - 12 JIC M</i>
4 Drain	1/2 inch BSP		
5 Motor 1			
6 Motor 2	<i>1 5/16 inch - 12 JIC M</i> 3/4 inch BSP M		
7 T connector	<i>1 1/16 inch - 12 JIC M</i>		<i>1 5/8 inch - 12 JIC M</i>

Italics denote connections supplied with Hydrives for North America.

* T junctions are offered on NPT HYDRIVE

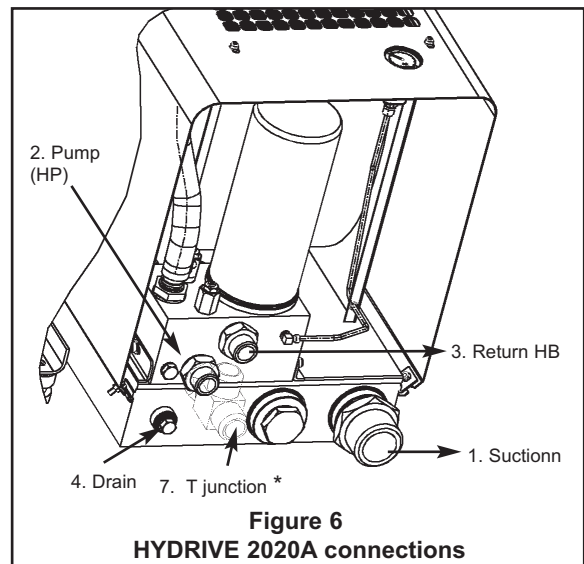

3. INSTALLATION (continued)

3.3 Hydraulic oil

The System must be filled with one of the following anti-foaming hydraulic oils, or an equivalent oil :

	Normal Ambient Température *	
	- 9°C to 26°C 15°F to 80°F	26°C and more 80°F and more
BP	ENERGOL HP32	ENERGOL HP46
SHELL	TELLUS 32	TELLUS 46
CASTROL	HYSPIN AWS 32	HYSPIN AWS 46
KENDALL	AW32	
ESSO	NUTO - H 32	NUTO - H 46
TOTAL	AZZOLLA 32	AZZOLLA 46

* For colder temperatures, use Kendal Glacial Blue, HYDRELF XV32 or equivalent cold weather Artic Grade hydraulic oil.

* Flush all hoses, fittings and the HYDRIVE tank with hydraulic oil prior to filling the HYDRIVE tank with hydraulic oil, using the following procedure :

1. Fill the HYDRIVE oil reservoir with suitable hydraulic oil (see examples above).
2. Disconnect HYDRIVE return hose at the HYDRIVE control valve block and provide a suitable container to collect waste hydraulic oil. Properly dispose of waste hydraulic oil.
3. Thoroughly flush the entire system, refilling the HYDRIVE reservoir as necessary, until free of all contamination.
4. Reconnect the HYDRIVE return hose.

NOTICE

DO NOT ALLOW DEBRIS TO ENTER THE HYDRAULIC SYSTEM DURING INSTALLATION OR SERIOUS DAMAGE TO SYSTEM COMPONENTS MAY OCCUR.

3.4 Priming the system



SET THE VEHICLE EMERGENCY BRAKE BEFORE ENGAGING THE PTO.

BEFORE Engaging the PTO follow these steps :

1. Fill the tank with the recommended hydraulic oil, until the oil reaches the black mark in the sight glass 6.
2. If the HYDRIVE is equipped with a selector valve, move the valve to the "NEUTRAL" (Center or Off) Position.
3. Non-spill (dry-break) couplings must be fully connected. Failure to do so can damage the hydraulic motor seals.

4. Have a container of suitable hydraulic oil available to refill the HYDRIVE reservoir as necessary. **DO NOT OVERFILL.**

NOTE

Do not fill the HYDRIVE reservoir while the hydraulic system is running. The level drops during operation and returns to the full level when not in operation.

5. Make sure the driven cargo pump (or compressor) is vented and cannot develop pressure.

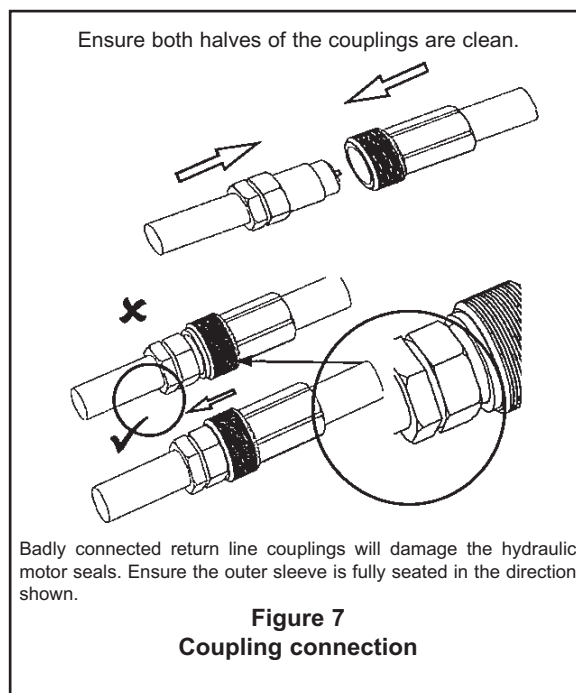

NOTICE

THE FOLLOWING SYSTEM PRIMING INSTRUCTIONS MUST BE FOLLOWED TO AVOID ENTRAPPING AIR.

1. Depress the clutch and engage the PTO. Release the clutch slowly. After approximately 2 seconds depress the clutch and disengage the PTO.
2. To insure that all system components, hoses and fittings are completely filled with hydraulic oil, crack the HYDRIVE return connection at the HYDRIVE control valve block (16a or b) allowing any trapped air to escape.
3. During the priming procedure, insure that the hydraulic oil does not drop below the RED mark on the HYDRIVE sight glass (6).
4. Operate any system selector valves and directional control valves to insure that all hoses and fittings are free of air.
5. Repeat steps 1 through 4 until system is fully primed.
6. Secure the HYDRIVE control valve block return connection.

3. INSTALLATION (continued)

3.5 Engaging hydraulic motor

1. Move the system on/off control valve or HYDRIVE selector valve (if equipped) and any directional valves to the correct position for running the hydraulic motor.
2. Increase tractor engine rpm to the required operating speed.

NOTICE

DO NOT OVERSPEED THE TRACTOR ENGINE, AS THIS WILL CAUSE SERIOUS DAMAGE TO SYSTEM COMPONENTS.

3. Inspect the hydraulic system for leaks. If any leaks are present, shut down the system immediately and repair as necessary. Return to the PRIMING THE SYSTEM section of this manual.
4. Following the procedure provided in the SETTING AND ADJUSTING FAN SPEED section of this manual, check the HYDRIVE fan to verify the factory setting.
5. Using an optical tachometer, check the speed of the driven unit. On engine-driven pump arrangements, insure the engine speed is governed to prevent overspeeding of the driven unit(s).

NOTICE

THE HYDRIVE MUST BE FREE OF VIBRATION, HYDRAULIC OR MECHANICAL, WHEN IN OPERATION, OR SERIOUS DAMAGE TO THE HYDRIVE COMPONENT PARTS WILL OCCUR.

3.6 Adjusting the relief valve



INCORRECT SETTINGS OF THE PRESSURE RELIEF VALVE CAN CAUSE SYSTEM COMPONENT FAILURE, PERSONAL INJURY, AND PROPERTY DAMAGE.

The HYDRIVE is equipped with a pressure relief valve that is factory set, the pressure value is stamped on the plate (see § TECHNICAL DATA).



These settings are suitable for the majority of applications. Insure that the HYDRIVE setting is functional with all ancillary equipment. **DO NOT** exceed lowest system component pressure rating or those of the hydraulic cooler. **ALWAYS** use an appropriately sized, calibrated pressure gauge when adjusting the pressure relief valve. The equipment required includes: 17 mm wrench and 5 mm hex socket key.

1. Install test equipment in the high pressure line per the manufacturers recommendations.

NOTE

The use of quick connect fittings in the hydraulic motor line allows easier installation of test equipment.

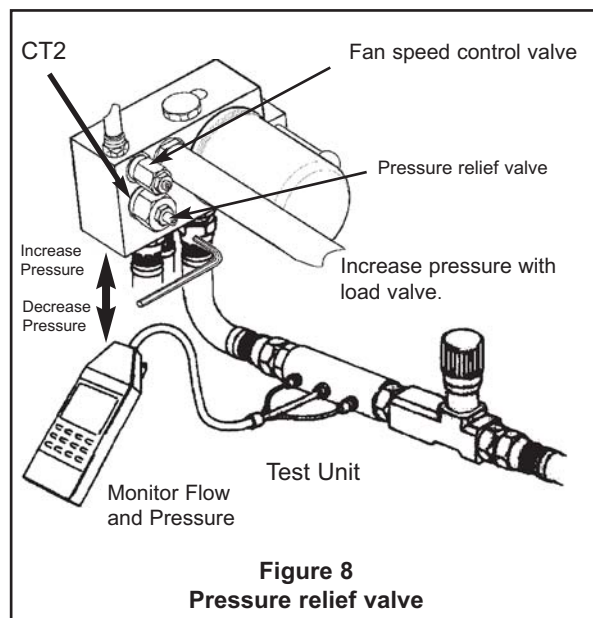

NOTE

If the HYDRIVE is equipped with the selector valve option, the test equipment can be inserted to either "MOTOR 1" or "MOTOR 2" pipe lines.

The selector valve must be positioned to select the line to which the test equipment is fitted.

2. With the system operating, and the driven unit(s) under no load, loosen the pressure relief valve lock-nut by turning it counter-clockwise, then turn the adjusting screw one full turn clockwise.
3. Increase system pressure by turning the tester load valve clockwise until a pressure of 10% ABOVE the system operating pressure is obtained.
4. Turn the HYDRIVE pressure relief screw counter-clockwise until a decrease in pressure is seen on the tester. Note the pressure at this point.
5. Tighten the pressure relief valve lock-nut, rechecking the pressure on the tester has not exceeded the pressure in step 4. If the pressure has changed, repeat steps 2 through 4 until the desired pressure has been obtained.
6. Turn OFF the system, bleed OFF all pressure, and remove the test equipment. Reinstall the high-pressure line.
7. Following steps 1 through 6 in the "Priming the System" section in this manual, refill and remove any trapped air.

NOTE

If the HYDRIVE pressure relief valve is set above the recommended 2500 PSI (170 bar) follow steps 1 through 4 of Setting and Adjusting HYDRIVE Fan Speed.

3. INSTALLATION (continued)

3.7 Setting HYDRIVE fan speed



FAN SPEEDS ABOVE 3000 RPM WILL CAUSE SERIOUS PERSONAL INJURY, DEATH OR MAJOR PROPERTY DAMAGE.

The HYDRIVE fan speed is factory set to 2800 rpm.

NOTE

The fan will not reach rated speeds without adequate system pressure.

Fan speed may be adjusted to control the HYDRIVE operating temperature.

The equipment required includes (see Figure 9) :

- optical tachometer,
- 4 mm allen key
- 13 mm wrench.

NOTICE

System components **MUST** be operating at full load to properly set the HYDRIVE fan speed.

NOTE

A minimum 725 PSI (50 bar) is required to operate the HYDRIVE fan. MOUVEX recommends the fan speed remain at the factory setting of 2,800 rpm.

1. Operate hydraulic system at full load to properly set HYDRIVE fan speed.

NOTE

Creating an artificial load of the factory relief valve setting, is the best way to set the fan speed. Refer to the **SETTING & ADJUSTING HYDRIVE RELIEF VALVE**, if necessary.

2. Loosen the fan speed lock-nut by turning counterclockwise.
3. While constantly checking the fan speed with an optical tachometer, decrease the fan speed by turning the adjusting screw counter-clockwise. Increase the fan speed by turning clockwise (see Figure 9).
4. When desired fan speed is obtained, tighten the lock-nut by turning it clockwise.
5. Unload system so that the fan speed slows or stops.
6. Reload the system and recheck the fan speed. Readjust if necessary.

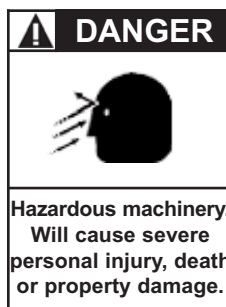
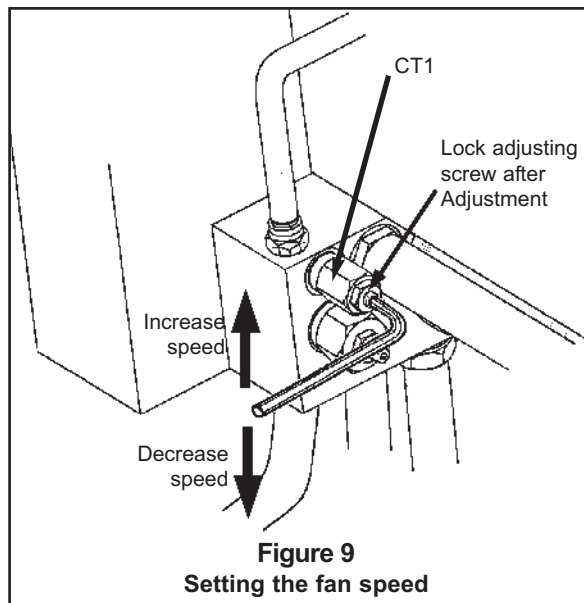

INSERTING ANY OBJECT INTO FAN DURING OPERATION WILL CAUSE SERIOUS PERSONAL INJURY, DEATH OR MAJOR PROPERTY DAMAGE.

4. OPERATION

4.1 HYDRIVE pre-start up check list

1. Check the HYDRIVE reservoir to make sure it is full of clean, uncontaminated oil, and that the level is no lower than the red mark in the sight glass (6).



QUICK RELEASE COUPLINGS MUST BE FULLY CONNECTED. FAILURE TO DO SO CAN CAUSE PERSONAL INJURY OR PROPERTY DAMAGE.

2. Check the radiator (44) for obstructions and dirt. Clean as necessary.
3. Move the selector valve (if equipped) to the "OFF" (Center or Neutral) position.



SET THE VEHICLE EMERGENCY BRAKE AND CHOCK WHEELS BEFORE ATTEMPTING MAINTENANCE OR SERVICE.

4.2 HYDRIVE operation

1. Set the tractor speed to idle RPM, depress the clutch and engage the PTO. Release the clutch SLOWLY.
2. If equipped, SLOWLY set the selector valve on the HYDRIVE from the "OFF" position to drive the required compressor or pump.
3. Set the tractor RPM to the required speed to obtain desired system operation. DO NOT overspeed the MOUVEX pump or compressor.
4. Inspect system for hydraulic oil leaks and for HYDRIVE fan operation. If leaks or incorrect fan operation are observed, shut down the system immediately. Repair as necessary.
5. When system operation has been stabilized, check the HYDRIVE operating temperature gauge, located on the tank oil level sight glass. Maximum recommended operating temperature for the HYDRIVE is 180°F (82°C).
6. The operator should remain nearby the equipment throughout the use to ensure the proper functioning of the system.

5. MAINTENANCE

NOTICE

HYDRIVE SERVICE SHALL BE PERFORMED BY QUALIFIED TECHNICIANS ONLY. SERVICE SHALL CONFORM TO ALL APPLICABLE LOCAL AND NATIONAL REGULATIONS AND SAFETY STANDARDS.

Before any work is performed on the HYDRIVE, remove the cover and thoroughly clean the unit to remove all traces of dirt. Do not allow water vapor to enter the hydraulic system during the cleaning process.

5.1 Maintenance schedule

After the first 10 hours of operation

1. Inspect hydraulic system for hydraulic oil leaks. If leaks are observed, shut down system immediately and repair as necessary.
2. Replace the HYDRIVE return filter (19).
3. Inspect all HYDRIVE mounting bolts, fittings and hoses. Tighten and replace as necessary.
4. Check the HYDRIVE fan speed and relief valve setting. Adjust as required, following the instructions in this manual.

Every 3 months

1. Follow the sections 1, 3 and 4 provided in the "After 10 hours of operation" section.
2. When the HYDRIVE hydraulic oil is cold, the oil restriction gauge (20) may read in the red area of the gauge. After the HYDRIVE warms to operating temperature, the oil restriction gauge **MUST** return to the GREEN level. If the reading fails to return to the GREEN level the return filter (19) **MUST** be replaced.
3. Inspect the HYDRIVE radiator (44) and fan (31) for damage. Carefully clean with air or steam. **DO NOT** remove the fan blade balancing clips.

Every 12 months

1. Follow ALL instructions provided in "Every 3 Months" section.
2. Replace hydraulic oil following the instructions provided in HYDRAULIC OIL and PRIMING THE HYDRIVE SYSTEM sections of this manual.

5.2 Return filter replacement

Check the return filter (19) at least every 3 months and replaced at least every 12 months (see Figure 10).

1. Remove filter by turning it counter-clockwise. If necessary use a filter wrench to remove canister. Properly dispose of the old filter element.
2. Install new filter element (19). **DO NOT** overtighten filter canister.
3. Refill the HYDRIVE reservoir following the instructions in the HYDRAULIC OIL and PRIMING THE HYDRIVE sections of this manual.

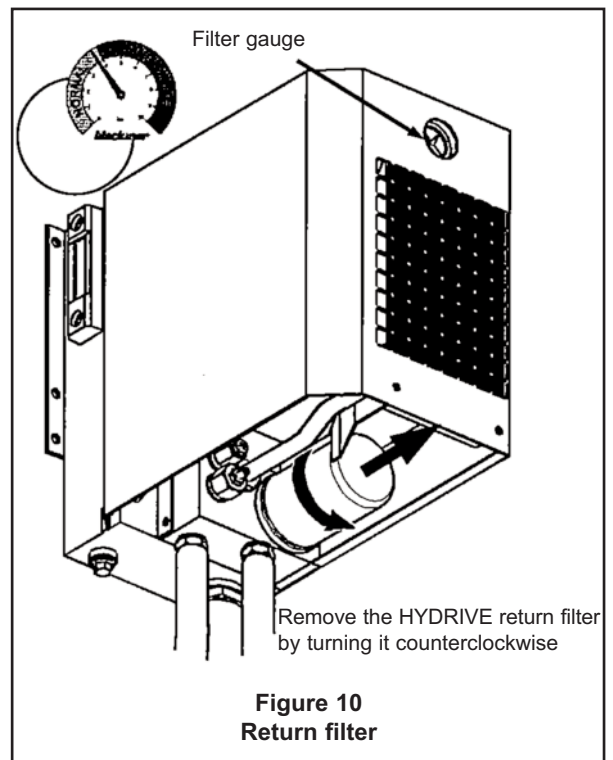

5.3 Fan replacement

The new fan (31) must be fitted on the hydraulic shaft (35) without forcing :

- Remove any burrs.
- Apply some grease.
- After tightening, check that it rotates perfectly round and doesn't touch the structure.

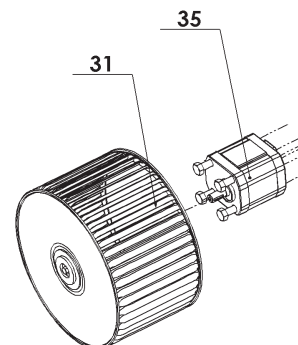

6. TROUBLESHOOTING

PROBLEM	CAUSE	CORRECTIVE ACTION
Aeration of the oil (Oil goes milky)	Insufficient oil getting to the pump.	See "Cavitation".
	Air entering the system.	See "Air Entering the System".
	Water entering the system.	Tighten up all hose connections. Inspect suction pipe for splits. Replace as required.
Air entering the system	Low oil level in the tank.	Fill reservoir and re-prime.
	Leaks in suction hose or fittings.	Tighten up all hose connections. Inspect suction pipe for splits. Replace as required.
Cavitation	Suction line too small.	Use large bore pipe.
	Suction line too long.	Move Hydrive closer to pump.
	Pump is higher than tank.	Re-position Hydrive to ensure there is a positive head pressure at the pump inlet.
	Suction line has too many restrictions or elbows.	Re-route pipe, and keep number of fittings to a minimum.
	Pump speed is too high.	Reduce pump speed or select smaller displacement pump.
Distorted / Cracked tank	Tank under strain from piping.	Install bulkhead fittings.
	Mounting surface is not flat.	Use shims (if necessary), to ensure a flat mounting surface.
	Tank damaged by mishandling.	Do not step on Hydrive or use to carry extra weight.
	Vibration.	See "Vibration".
High/excessive circuit pressure	Incorrect hydraulic pump selection.	Re-check hydraulic calculations.
	Driven unit requires higher torque.	Check driven unit for seizure or blocked lines.
	Insufficient fan speed.	Check fan speed. Adjust if required.
High/excessive oil temperature	Radiator blocked.	Clean radiator.
	Relief valve opening.	See "Relief valve problems".
	Cold start bypass opened.	Clean cold start bypass.
Motor seals damaged or leaking	Seals worn.	Repair or replace.
	Drain line not connected.	Install case drain and replace motor seals.
	Excessive return line pressure.	See "Return line pressure too high".
	High oil temperature.	See "Excessive oil temperature".
Motor not turning at correct speed	Relief valve opening.	See "Relief valve problems".
	Pump or motor damaged.	Overhaul unit.
	Driven unit seized or blocked.	See manual for driven unit.
	System design.	Re-check hydraulic calculations.
Pump leaks	Seals worn.	Repair or replace.
	Excessive circuit pressure	See "Excessive circuit pressure".
Radiator burst	Return pressure too high	See "Return pressure too high".
Return pressure too high	Return line too small.	Increase pipe size.
	Return line too long.	Reposition Hydrive.
	Excessive flow.	Reduce speed of driven unit.
	Blocked return.	Replace return filter.
	Improperly installed quick release couplings.	Ensure couplings are properly installed.
Relief valve problems	Continuously opening.	Reset the valve 10% above circuit pressure.
	Sticking or un-settable relief valve.	Replace with new relief valve.
Vibration Hydraulic	Relief valve opening intermittently.	See "relief valve problems".
	Aeration of the oil.	See "Aeration of oil".
Vibration - Vehicle	Normal vibration from vehicle.	Use anti vibration mounts to isolate Hydrive.
	Whole vehicle vibrates badly.	Ensure engine is not mis-firing.

7. STORAGE CONDITIONS

The equipment must be systematically stored in an area sheltered from bad weather.

The equipment must bear its original protective components until it is installed in its final application.

If installation is interrupted, put back in place the original protective components or equivalent components.

8. SCRAPPING

The cooler must be scrapped in compliance with the regulations in force.

During this operation, particular care must be paid to the drainage stages of the cooler.



MOUVEX sas, ZI La Plaine des Isles – 2 Rue des Caillottes – 89 000 Auxerre France, déclare que l'équipement suivant / declares the following equipment / erklärt, dass folgende Ausrüstung:

Modèle : _____ (A) Répondant aux spécifications indiquées dans l'ARC N° : _____ (B)
Designation / Bezeichnung Serial N° / Serien Nr According to the specifications recorded in the acknowledgment of order N° :
Entsprechend den Spezifikationen aus AB-Nr :

Pour la Sté MOUVEX sas, fait à Auxerre le : _____
For Mouvex sas company – Date : _____
Für die Fa Mouvex sas - Datum : _____

Jean-François FOUJIN - Responsable Qualité
Quality Manager / Qualitätsbeauftragter

- Configuration :**
Konfiguration
- Pompe / Compresseur arbre nu (Pump / Compressor « bare-shaft »)
(Pumpe / Kompressor, freies Wellenende)
- Groupe de pompe / de compression (Pumping Unit / Compressor Unit)
(Pumpen- / Kompressoraggregat)
- Type / Geräteart :**
- Pompe à mvt excentré (Eccentric Disc Pump / Ringkolbenpumpe)
- Pompe péristaltique (Peristaltic Pump / Schlauchpumpe)
- Pompe centrifuge (Centrifugal Pump / Kreiselpumpe)
- Pompe à lobes (Lobes Pump / Drehkolbenpumpe)
- Pompe à palettes (Vanes Pump / Flügelzellenpumpe)
- Autre pompe (Other Pump / Andere Pumpe)
- Compresseur à Vis (Screws compressor / Schraubenverdichter)
- Compresseur à palettes (Vanes compressor / Flügelzellenverdichter)
- Réfrigérant Hydraulique (Hydraulic oil cooler / Hydraulikkühler)

Est conforme aux dispositions suivantes :

- Directive « MACHINES » 2006/42/CE et aux législations nationales la transposant, portant sur les dispositifs de sécurité liés aux risques mécaniques et électriques applicables aux machines tournantes.
NF EN 809:2009 NF EN 1672-2:2009 NF EN ISO 13857:2008 NF EN 12162:2009
- Directive « ATEX » 94/9/CE du 23 mars 1994 et aux législations nationales la transposant, portant sur les appareils destinés à être utilisés en atmosphères explosibles. Conformité obtenue par application des normes :
NF EN 1127-1:1997 NF EN 13463-1:2009 NF EN 13463-5:2009 Certification ATEX délivrée par INERIS*, Organisme Certificateur, et portant le marquage suivant : (C)

Is in conformity with the provisions of the following Directive:

- « MACHINES » Directive 2006/42/EEC as transposed by the national legislation, concerning safety equipments and arrangements relative to mechanical and electric risks applicable to rotative machines.
NF EN 809:2009 NF EN 1672-2:2009 NF EN ISO 13857:2008 NF EN 12162:2009
- « ATEX » Directive 94/9/EC (23 march 1994) as transposed by the national legislation, concerning equipment intended to be used in explosive atmospheres. Conformity obtained by application of the standards :
NF EN 1127-1:1997 NF EN 13463-1:2009 NF EN 13463-5:2009 ATEX Certification delivered by INERIS*, Notified Body, and with the following marking: (C)

den Bestimmungen der nachstehenden Richtlinien entspricht:

- „Machines-Richtlinie“ 2006/42/EEC wie umgesetzt im nationalen Recht hinsichtlich der Ausrüstungssicherheit und Sicherheitsvorkehrungen bezogen auf mechanische und elektrische Risiken, die für rotierende Maschinen gelten.
NF EN 809:2009 NF EN 1672-2:2009 NF EN ISO 13857:2008 NF EN 12162:2009
- „ATEX“ Richtlinie 94/9/EG (23. März 1994) wie umgesetzt im nationalen Recht in Bezug auf Ausrüstungen für den Einsatz in explosionsgefährdeter Atmosphäre. Die Konformität hat Geltung durch Anwendung folgender Normen:
NF EN 1127-1:1997 NF EN 13463-1:2009 NF EN 13463-5:2009 Die ATEX-Zertifizierung wurde von der benannten Stelle INERIS* erteilt, und mit folgender Kennzeichnung: (C)



Temp Max produit pompé / Max Temp Flow / Max. T° Medium = _____ °C

L'équipement désigné ci-dessus doit être utilisé conformément à l'utilisation qui en a été prévue de par sa conception et sa fabrication, et conformément aux normes en vigueur.
Nous, soussignés, déclarons que l'équipement concerné est conforme aux Directives listées ci-dessus et aux normes applicables s'y rapportant.

The equipment indicated above must be used according to the foreseen use by its design and its manufacturing, and according to the current standards.
We, undersigned, declare that the concerned equipment is in conformity with the Directives listed above and in the applicable standards in force.

Oben stehend bezeichnete Ausrüstung ist entsprechend dem durch Konstruktion und Fabrikation vorgesehenen Verwendungszweck und entsprechend den geltenden Normen einzusetzen.
Die Unterzeichner erklären, dass die bezeichnete Ausrüstung den oben aufgeführten Richtlinien und den diesbezüglich geltenden Normen entspricht.